

2009/3860

lukom 2010-08-24
(epost från Stadsryik)



Canadian Nuclear
Safety Commission

Commission canadienne
de sûreté nucléaire

UNPROTECTED/NON PROTÉGÉ

(ORIGINAL /ORIGINAL)

CMD: 10-H19

Date signed/Signé le: 20 08 2010

Reference CMDs/Les CMD de référence: 10-H19.A

Bruce Power

Bruce Power

One-Day Public Hearing

Audience publique d'une journée

Scheduled for:
September 29, 2010

Prévue pour :
29 septembre, 2010

Request for a Licensing Decision:

Demande d'autorisation :

Regarding:
A New Licence

Relative à :
Un nouveau permis

Submitted by:
CNSC Staff

Soumise par :
Le personnel de la CCSN

E-DOCS #: 3596609

Canada

Summary

This CMD presents information about the following matters of regulatory interest with respect to Bruce Power:

- Bruce Power has applied for a licence to package and transport under special arrangement, 16 steam generators to Sweden

The following actions are requested of the Commission:

- As documented in the attached, Canadian Nuclear Safety Commission (CNSC) staff reviewed the application request and recommends that the Commission consider and decide on the application whether the Commission will issue Bruce Power transport licence number TL-SX-40039.01.00/2010 and special arrangement certificate number CDN/5255/X-96 (Rev.0).

Résumé

Le présent CMD présente de l'information sur un ensemble de questions d'ordre réglementaire concernant Bruce Power:

- Bruce Power a soumis une demande de permis pour l'emballage et le transport de 16 générateurs de vapeur vers la Suède sous arrangement spécial

La Commission pourrait considérer prendre les mesures suivantes:

- Tel qu'expliqué dans le présent document, le personnel de la Commission canadienne de sûreté nucléaire (CCSN) a examiné la demande de permis et recommande que la Commission étudie la demande et décide si la Commission émettra le permis de transport numéro TL-SX-40039.01.00/2010 et le certificat d'homologation pour arrangement spécial numéro CDN/5255/X-96 (Rév.0).

Signed/signé le

20 08 2010



André Régimbald

Director General

Directorate of Nuclear Substance Regulations

Directeur général de la

Direction de la réglementation des substances nucléaires

TABLE OF CONTENTS

EXECUTIVE SUMMARY	1
OVERVIEW.....	3
1.1. Background	3
1.2. Steam Generators	5
1.3. The Need for a Special Arrangement.....	7
2.0 REGULATORY REQUIREMENTS.....	7
2.1. National Regulations	8
2.2. International Regulations.....	8
3.0 TRANSPORT LICENSING PROCESS	8
3.1. Designated Officer Functions	8
3.2. Referral to the Commission.....	9
4.0 ASSESSMENT OF SAFETY CONTROL AREAS.....	9
4.1. Packaging and Transport	9
4.2. Radiation Protection	19
4.3. Environmental Impact.....	21
4.4. Emergency Measures	23
4.5. Security	24
5.0 CONSULTATION.....	24
6.0 OVERALL CONCLUSION	24
7.0 RECOMMENDATION TO THE COMMISSION.....	25
REFERENCES.....	26
LIST OF ACRONYMS.....	27
DEFINITIONS	28
APPENDIX A: DRAFT TRANSPORT LICENCE TL-SX-40039.01.00/2010.....	30
APPENDIX B: DRAFT CERTIFICATE CDN/5255/X-96 (REV. 0)	32

EXECUTIVE SUMMARY

In April 2010, the CNSC received an application from Bruce Power seeking CNSC approval for the transport of 16 steam generators to a Swedish facility, operated by Studsvik, that specializes in recycling of contaminated metal. Bruce power submitted this application under the requirements of the *Packaging and Transport of Nuclear Substances* (PTNS) Regulations, Transport Canada *Transportation of Dangerous Goods* (TDG) Regulations and the International Atomic Energy Agency Regulations, *Regulations for the Safe Transport of Radioactive Material*, TS-R-1.

Highly qualified specialists to include Transport Specialists who are designated as professional engineers among CNSC's staff carefully reviewed, evaluated, and assessed the application. After evaluating Bruce Power's application, CNSC staff collected further data and independently analyzed it. Based on their comprehensive assessment, CNSC staff conclude that this application is very low risk due to the negligible radiological impact on the workers, the public and the environment. Their evaluation covered topics including steam generators characterization, verification of the external surfaces, compensatory measures, security, emergency measures, radiation protection, and environmental impact.

CNSC staff assessed the radiological characterization and the fact that the contamination is confined to the inside of the steam generators. They concluded that the steam generators are classified as Surface Contaminated Object – Group 1 (SCO-1), the lowest categorization under the *Packaging and Transport of Nuclear Substances Regulations* applicable to surface contaminated objects.

Both Bruce Power's initial findings and CNSC staff's independent verification of those findings indicate that the external surfaces of the steam generators have not shown radiological contamination. They concluded that there is no presence of radiological material on the surface of these steam generators.

CNSC staff evaluated the proposed compensatory measures for the transport of the steam generators and concluded that the proposed measures are adequate for the level of risk associated with the shipment. CNSC staff conclude that the proposed compensatory measures would ensure that the overall level of safety during transport and during storage in transit would meet the applicable requirements.

CNSC staff reviewed and evaluated the security and emergency measures that would be in place for this shipment to protect the health and safety of the workers and the public. These were found to be acceptable.

Members of the public, such as people driving or walking by the steam generators while they are in transit on the highway, would not receive any measureable radiation dose. The drivers of the vehicles would be wearing personal dosimetry equipment to measure the "whole-body" and "skin" doses they may receive. Furthermore, access to the steam generators would be controlled at all times.

In addition to the environmental assessment that was prepared in 2006 as part of the refurbishment of the Bruce Unit 1 and 2, CNSC staff performed an additional assessment of the project to consider whether adequate measures for the protection of the environment would be in place. CNSC staff concluded that under the normal or expected conditions of transport, there would not be an impact on the health and safety of persons and the environment because all contamination is sealed within the steam generators.

CNSC staff recommend that the Commission approve:

- The attached proposed transport licence number TL-SX-40039.01.00/2010 for the transport of the 16 steam generators to Sweden
- The attached proposed transport certificate number CDN/5255/X-96 (Rev.0) for the transport of the 16 steam generators to Sweden.

CNSC staff recommend that the licence and certificate be issued for a period of 1 year.

OVERVIEW

1.1. Background

In April 2010, the CNSC received an application from Bruce Power seeking CNSC approval for the transport of 16 steam generators to a Swedish facility, operated by Studsvik that specializes in recycling of contaminated metal. Bruce Power submitted this application under the requirements of the *Packaging and Transport of Nuclear Substances* (PTNS) Regulations, Transport Canada *Transportation of Dangerous Goods* (TDG) Regulations and the International Atomic Energy Agency (IAEA) Regulations, *Regulations for the Safe Transport of Radioactive Material*, TS-R-1.

The application is for a licence to package and transport under special arrangement in accordance with section 5 of the *Packaging and Transport of Nuclear Substances* (PTNS). Such a licence is required because the size of the steam generators makes it impractical to package them; the interior cannot be accessed which does not allow direct confirmation of the estimated internal surface contamination levels and the total activity in the shipment is estimated to exceed the consignment limits of the regulations for Surface Contaminated Objects material transported onboard a single ship. In addition, the shipment requires a security plan approved by the CNSC.

This application is considered very low risk in nature due to the negligible radiological impact on the workers, the public and the environment. Hence, it falls under the CNSC PTNS Regulations category of Surface Contaminated Object, Group-1 (SCO-I), the lowest category found in the regulations. This classification is based on the following regulatory criteria: the non-fixed and fixed contamination in inaccessible areas which does not exceed 4×10^4 Bq/cm² in any 300 cm² for beta and gamma emitters and low toxicity alpha emitters and 4×10^3 Bq/cm² for other alpha emitters.

Based on the radiological characterization and the fact that the contamination is confined to the inside of the steam generators, the steam generators are within these regulatory criteria (see section 3.1.2 for details).

As part of a CNSC field inspection, staff performed wipe tests to verify the external surfaces of the steam generators for the presence of contamination. The results of the analysis performed by the CNSC laboratory have shown no radiological contamination, hence there is no presence of radiological material on the surface of these steam generators.

CNSC policy document P-290 *Managing Radioactive Waste* and guidance document G-219 *Decommissioning of Nuclear Facilities* state that the generation of radioactive waste should be minimized to the extent practicable and that the waste management plan should include provisions for the reuse, recycling storage or disposal of the waste. Licensees are encouraged to submit new proposals which take into consideration new and emerging technologies in an effort to reuse and recycle radioactive waste and, at the same time, to minimize the risk to the health and safety of persons and the environment. This recycling initiative as proposed by Bruce Power is in line with CNSC policy direction since the end result would be a reduction of 90% in the

total volume of the existing full size generator, hence represents a good environmental waste management practice.

Studsvik was selected by Bruce Power as it has extensive experience in processing large structures containing low and intermediate level radioactive components. The company is also involved in various other technical activities related to the nuclear power industry, with operations in Sweden, Germany, the U.K. and the USA. Studsvik's Swedish facility, located near the city of Nyköping in the South, is specialized in processing metal from components arising from various refurbishment projects – notably from customers from Germany, Finland, the U.K. and Sweden. This facility is a licensed entity in good standings with the Swedish Radiation Safety Authority.

At Studsvik's facility in Sweden, metallic waste is decontaminated, segmented and melted. This process removes the radioactivity and minimizes the volume of residual waste for disposal; melting the metal scrap reduces the volume and weight of the waste. The cleaned end-product is metal ingots, which can either be immediately free-released as conventional scrap metal or released after a period of decay storage. Residual products and ingots that cannot meet the clearance criteria are returned to the customer. Studsvik's operations are covered by management systems accredited in accordance with ISO 14001 and ISO 9001.

The licence application for the transport of these generators from Canada to Sweden under special arrangement is made in accordance with section 5 of the *Packaging and Transport of Nuclear Substances* (PTNS) Regulations. Section 5 of the PTNS Regulations makes reference to the IAEA TS-R-1 Regulations which describe the considerations to be taken into account in order to achieve a level of safety that is equal to or greater than what is required under the regulations.

1.2. Steam Generators

In general steam generators are not radioactive in nature; they become contaminated with radioactivity in their useful life in a nuclear power plant. Steam generators are commonly upgraded or changed during maintenance or refurbishment activity at a nuclear power plant.

The steam generators as shown in Figure 1 and 2 are large steel U-tube heat exchangers. Each generator is approximately 11.7 meters in length by 2.5 meters in diameter and weighs about 100 metric tons. The generators were qualified as pressure retaining components when in use and have a 54-millimetre thick exterior steel wall. There are 4,200 Inconel (stainless steel) tubes inside each steam generator. The Inconel tubes measure about 14 meters in length by 11 millimetres in diameter. These tubes are the components that had the most exposure to radioactivity when the steam generators were in use. Therefore, it is mostly the interior of these tubes that is contaminated with radioactive material. All openings of the steam generators have been sealed with welded steel closure plates to provide containment of the radioactive material.

Of the 16 steam generators referred to in the Bruce Power application, eight were decommissioned from Unit 2 in 1995 and the other eight were decommissioned from Unit 1 in 1997. All 16 steam generators were safely stored on site and moved to the Western Waste Management Facility (WWMF) within the Bruce site in 2007. The WWMF is licensed by the Canadian Nuclear Safety Commission and located near Bruce Power's facility. The WWMF is owned and operated by the Ontario Power Generation (OPG).

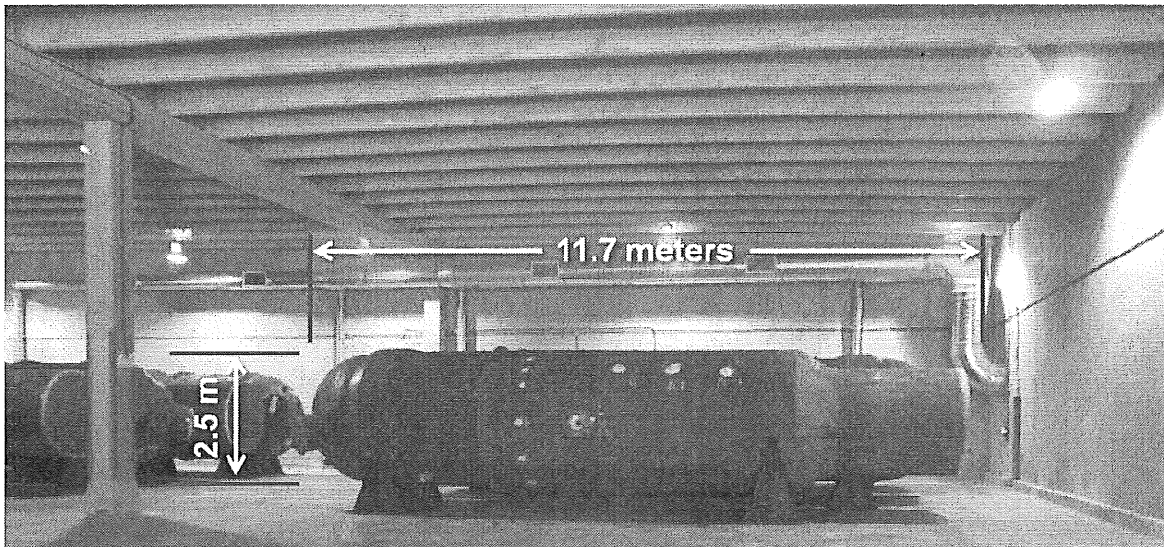

Figure 1: Steam generator inside the dedicated storage building at the WWMF

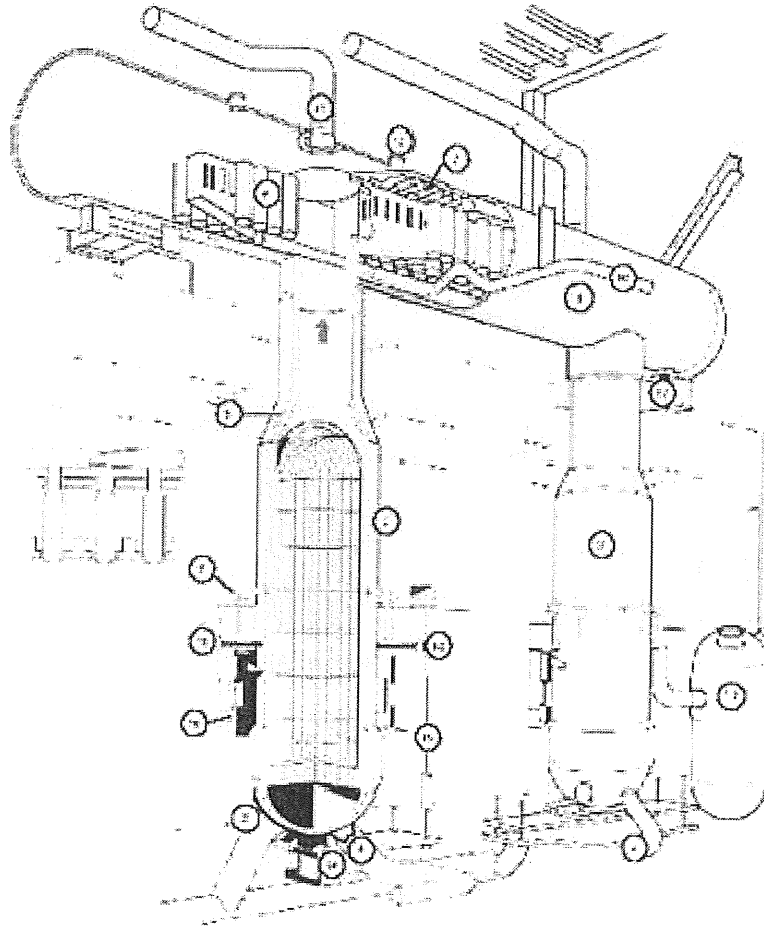

Figure 2: Cutaway view of a steam generator as installed in the facility

When the generators were prepared for shipment from the plant to the WWMF, all of their openings were welded closed (Figure 3). The welding was completed in accordance with the *ASME Boiler and Pressure Vessel Code*. In addition, the welds were tested using non-destructive methods in accordance with *ASME Boiler and Pressure Vessel Code* to ensure their integrity. These tests conducted in 2007 used magnetic particle examination and all areas inspected were found to conform to code requirements.

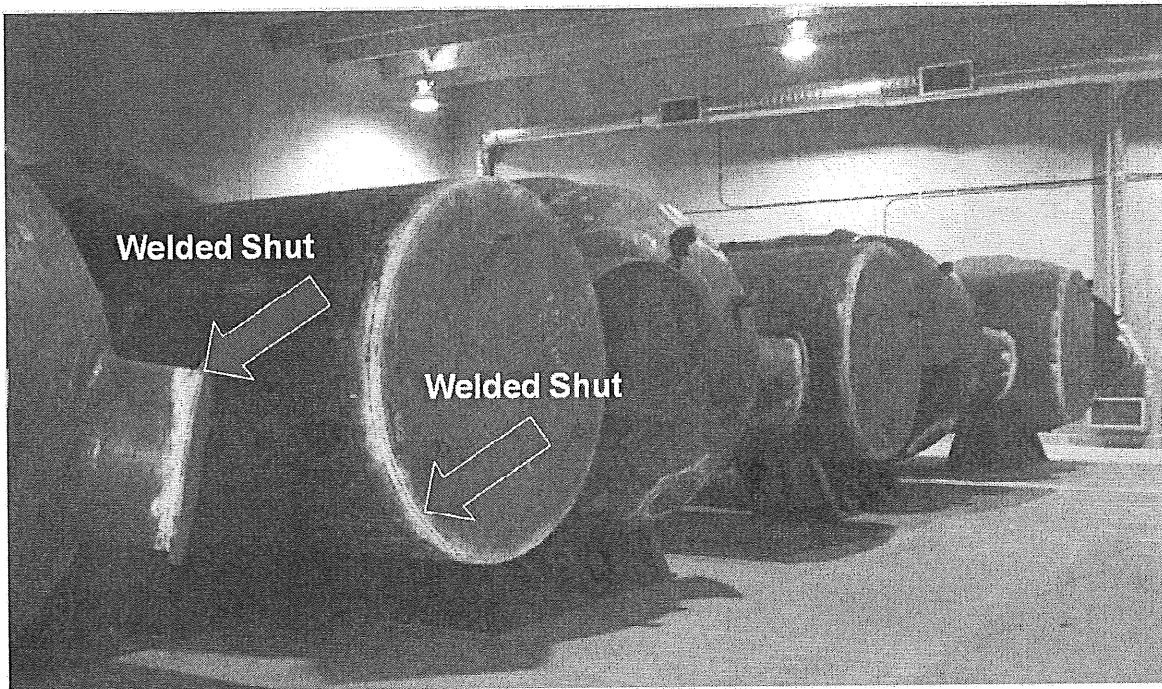

Figure 3: Welding of the openings of the steam generators

1.3. The Need for a Special Arrangement

In general, the transport of nuclear substances must be done safely and securely in accordance with the PTNS Regulations. At times there are special cases where the material containing nuclear substances can not be transported in packages or containers that have been designed to meet all of the applicable transport requirements under the PTNS Regulations.

In such cases, the applicant is required to submit an application for a special arrangement as required in Section 5 of the PTNS Regulations. The applicant must demonstrate to the CNSC that the shipment meets the criteria for special arrangement and that the proposed level of safety equals or exceeds the provisions listed under PTNS Regulations.

Bruce Power has applied for a licence to transport under special arrangement for the transport of the steam generators because the size of the steam generators makes it impractical to package them, the interior cannot be accessed which does not allow direct confirmation of the estimated internal surface contamination levels, and the total activity in the shipment is estimated to exceed the limits of the regulations for Surface Contaminated Objects material transported onboard a single ship.

2.0 REGULATORY REQUIREMENTS

CNSC staff evaluated the application against the applicable national and international transport regulations.

2.1. National Regulations

The transport of nuclear substances in Canada is regulated by the CNSC and Transport Canada. Accordingly, the transport of the steam generators must meet the requirements set forth in the *CNSC Packaging and Transport of Nuclear Substances Regulations* which incorporate by reference the *International Atomic Energy Agency (IAEA) TS-R-1 Regulations for the Safe Transport of Radioactive Material*.

In addition, CNSC evaluates that the shipment must comply with the *Transportation of Dangerous Goods Regulations* administered by Transport Canada. These regulations apply to all dangerous goods and make reference to the CNSC PTNS Regulations for the transport of radioactive material as Class 7 Dangerous Goods.

Under Transport Canada's regulations, certain shipments of nuclear substances require an Emergency Response Assistance Plan (ERAP). Due to the inherent low risk, the shipment of the steam generators does not require an ERAP under the *Transportation of Dangerous Goods Regulations*. However, CNSC staff requested an Emergency Response Plan (ERP) from the applicant. Bruce Power has submitted the ERP in order to cover the shipment of these steam generators. The plan covers the road shipment as well as the marine portion. CNSC staff evaluation of this plan is discussed in Section 4.4.

CNSC staff concluded that the shipment complies with the requirement of the CNSC PTNS regulations as well as Transport Canada's *Transportation of Dangerous Goods Regulations*.

2.2. International Regulations

CNSC staff also reviewed this application to ensure compliance with the IAEA *TS-R-1* regulations as well as the *International Maritime Dangerous Goods (IMDG) Code* under the International Maritime Organization (IMO) as this is an international shipment.

CNSC staff concluded that the shipment complies with all of the above stated international regulatory requirements.

Under the IAEA *TS-R-1* Regulations and the IMDG Code, this transport requires approval by all countries where the shipment would go through or into in addition to Canada. This includes the United States and Sweden. Bruce Power is responsible for obtaining these approvals. The United States Department of Transportation and the Swedish Radiation Safety Authority will conduct similar reviews of the application from Bruce Power, and will also consider the decision of the CNSC before making their own decision on this application.

3.0 TRANSPORT LICENSING PROCESS

3.1. Designated Officer Functions

The decision for a licence to transport radioactive materials would normally be made by a Designated Officer (DO). DOs are authorized by the Commission under Section 37 of the *Nuclear Safety and Control Act* (NSCA) to exercise this authority. Paragraph 37(2)(c) of the

NCSA provides that the Commission may authorize a DO to issue a licence of a class established by the Commission. In 2000, the Commission established transport licences as one of the classes of licences that a DO is authorized to issue.¹ The Commission confirmed the authority in February 2008 in CMD 08-M10. All transport licences have been issued by DOs since the enactment of the NSCA in 2000.

Upon receipt of an application to package and transport under special arrangement, CNSC transport specialists, who must be accredited as Professional Engineers, with the expertise of other CNSC staff, evaluate the information submitted to determine if the overall level of safety in transport would be at least equivalent to that which would be provided if all the applicable regulatory requirements had been met. Once this has been determined, the CNSC (normally the Designated Officer) first issues a Certificate for Special Arrangement for the package in accordance with paragraph 21(1)(h) of the *Nuclear Safety Control Act*; Section 5 of the *Packaging and Transport of Nuclear Substances Regulations*, and to the 1996 Edition (Revised) of the *IAEA Regulations for the Safe Transport of Radioactive Material*. Following the issuance of the Certificate for Special Arrangement, the CNSC (normally the Designated Officer) then issues a licence to transport under Special Arrangement to the applicant for the shipment in accordance with paragraph 6(1)(d) of the *Packaging and Transport of Nuclear Substances Regulations*.

3.2. Referral to the Commission

In this case, CNSC staff has concluded that there are no safety significant issues associated with the proposed shipment. However, in light of public concerns and the value of ensuring both a proper understanding of the scope of the undertaking and the presentation of accurate information relating to the health, safety and security, the Designated Officer has asked that the Commission review the application at a one-day public hearing. Additionally, the proceedings will allow the public to participate as interveners and present their views to the Commission Tribunal members for their consideration.

4.0 ASSESSMENT OF SAFETY CONTROL AREAS

4.1. Packaging and Transport

In order to obtain a licence to transport under special arrangement, the CNSC must be satisfied that the overall level of safety during transport is equivalent to or exceeds the applicable regulatory requirements under PTNS Regulations. The areas covered by the review include:

- Characterization of the nuclear substances present in the shipment and the classification of the material in accordance with the classification specified in the PTNS Regulations
- The proposed packaging to ensure that it is appropriate for the material to be transported and that it reflects the type of package associated with the classification of the material
- The overall transportation plan to verify that all transportation aspects have been taken into account in the evaluation

¹ See part I of CMD 01-M17, which amended CMD 00-M16 issued in 2000.

- The compensatory measures that are proposed for the shipment to account for the deviations requested in the application for the licence to transport under special arrangement
- The security plan that would be in place to cover this shipment.

4.1.1 Characterization of the Nuclear Substances

The total activity contained in the 16 steam generators has been estimated at 3.67 TBq as of June 30, 2010. Table 1 provides details on the nature of the activity as of June 30, 2010 and the quantity, in grams of the nuclear substances present in each steam generator from Unit 1 and Unit 2.

Table 1: Inventory of nuclear substances in one steam generator

ISOTOPE	SPECIFIC ACTIVITY Bq/g	ACTIVITY UNIT 1 (MBq*)	ACTIVITY UNIT 2 (MBq*)	UNIT 1 WEIGHTS (g)	UNIT 2 WEIGHTS (g)
Am-241	1.27E+11	16,100	13,200	0.126033	0.103412
Am-243	7.39E+09	16	18	0.002162	0.002432
C-14	1.65E+11	1,500	12,000	0.009065	0.072501
Cm-244	3.00E+12	8,240	1,080	0.002644	0.000347
Co-60	4.19E+13	84,700	41,800	0.001781	0.000881
Cs-137	3.23E+12	821	783	0.000249	0.000238
Eu-154	9.78E+12	291	247	0.000027	0.000023
Fe-55	8.93E+13	24,300	33,300	0.000272	0.000290
H-3	3.58E+14	21,500	19,200	0.000057	0.000051
Hf-181	6.30E+14	674	652	0.000001	0.000001
I-129	6.55E+06	0.000390	0.000390	0.000060	0.000060
Nb-94	6.95E+09	15	15	0.002159	0.002158
Ni-59	3.00E+09	520	110	0.173601	0.036723
Ni-63	2.20E+12	66,900	14400	0.030194	0.006526
Np-237	2.61E+07	0.75	0.87	0.028703	0.033295
Pu-238	6.35E+11	4,800	3,010	0.007507	0.004703
Pu-239	2.31E+09	4,900	5,700	2.124977	2.471769
Pu-240	8.45E+09	6,990	8,090	0.827304	0.957105
Pu-242	1.46E+08	7.1	8.2	0.048762	0.056317
Sb-125	3.83E+13	41.1	2.47	0.000001	0.000001
Sr-90	5.06E+12	47,100	39,300	0.009097	0.007581
Tc-99	6.29E+08	0.09	0.058	0.000143	0.000092

* 1 MBq is equivalent to 1×10^6 Bq

CNSC staff performed an evaluation of the inventory of the nuclear substances present and concluded that the activity contained within the steam generator has been adequately estimated.

4.1.2 Classification of the Steam Generators under the PTNS Regulations

As indicated previously, the steam generators are non-radioactive equipment in nature. During their service life within the reactor station, they became slightly contaminated with radioactive metal oxides on their inside surfaces. The estimate of the internal contamination in the steam generators presented by Bruce Power, classifies the steam generators as Surface Contaminated Objects – Group 1 (SCO-I). This is the lowest classification of surface contaminated objects as defined in the PTNS Regulations and is an indication of the low level of risk associated with the transport of these vessels.

Surface Contaminated Object Group-1 (SCO-I) is defined as a solid object which is not itself radioactive but which has radioactive material distributed on its surface where:

- The non-fixed contamination on the accessible surfaces does not exceed 4 Bq/cm^2 in any 300 cm^2 for beta and gamma emitters and low toxicity alpha emitters and 0.4 Bq/cm^2 for other alpha emitters.
- The fixed contamination on the accessible surfaces does not exceed $4 \times 10^4 \text{ Bq/cm}^2$ in any 300 cm^2 for beta and gamma emitters and low toxicity alpha emitters and $4 \times 10^3 \text{ Bq/cm}^2$ for other alpha emitters.
- The non-fixed and fixed contamination in inaccessible areas does not exceed $4 \times 10^4 \text{ Bq/cm}^2$ in any 300 cm^2 for beta and gamma emitters and low toxicity alpha emitters and $4 \times 10^3 \text{ Bq/cm}^2$ for other alpha emitters.

For the steam generators, the applicable values are $4 \times 10^4 \text{ Bq/cm}^2$ in any 300 cm^2 for beta and gamma emitters and low toxicity alpha emitters, and $4 \times 10^3 \text{ Bq/cm}^2$ for other alpha emitters as the contamination is contained within the steam generators and not accessible.

Bruce Power provided the results of the radiological characterization of the steam generators used to estimate the total contamination level in inaccessible areas within the eight steam generators from Unit 1 which were removed from service in 1997. It is estimated that the total quantity of contamination in each steam generator is $10.4 \times 10^3 \text{ Bq/cm}^2$ or 26% of the limit, for beta gamma and low toxicity alpha emitters, and $1.7 \times 10^3 \text{ Bq/cm}^2$, or 42% of the limit for all other alpha emitters. Values from the steam generators removed from Unit 2 show levels of contamination slightly below those of Unit 1, as those were removed from service in 1995.

Table 2: Fraction of the contamination limits for SCO-1 material

TYPE OF EMITTER	REGULATORY LIMIT FOR SCO-1 MATERIAL	UNIT 1 STEAM GENERATORS	FRACTION OF THE LIMIT
Beta, gamma and low toxicity alpha	$40 \times 10^3 \text{ Bq/cm}^2$	$10.4 \times 10^3 \text{ Bq/cm}^2$	26%
Other alpha emitters	$4 \times 10^3 \text{ Bq/cm}^2$	$1.7 \times 10^3 \text{ Bq/cm}^2$	42%

CNSC staff verified, recalculated and assessed the assumptions used in the application and confirmed the decay calculations performed by the applicant.

CNSC staff concluded that the steam generators should be classified as SCO-I material as per the Regulations.

4.1.3 Packaging Evaluation

The PTNS Regulations take into account the risks from both normal and accident conditions of transport in the classification of the material and the associated packaging requirements. For the transport of the steam generators under special arrangement the overall level of safety in transport is required to be equivalent to or better than what would be required under the applicable regulatory requirements.

4.1.4 Current state of the steam generators

The application specifies that the packaging requirements cannot be met due to the size of the generators and that the IAEA Regulations do not include provisions to accommodate large components with internal surface contamination such as the steam generators except under special arrangement shipments. For this shipment, the packaging is based on the nature of the components which have a thick external steel shell that provides containment for the nuclear substances. All openings of the steam generators have been sealed with welded steel closure plates to provide containment of the radioactive material (Figure 4). The welding was completed in accordance with Section IX of the ASME *Boiler and Pressure Vessel Code* and the welds were tested in accordance with the ASME *Boiler and Pressure Vessel Code* Section 3 Division 1 to ensure their integrity.

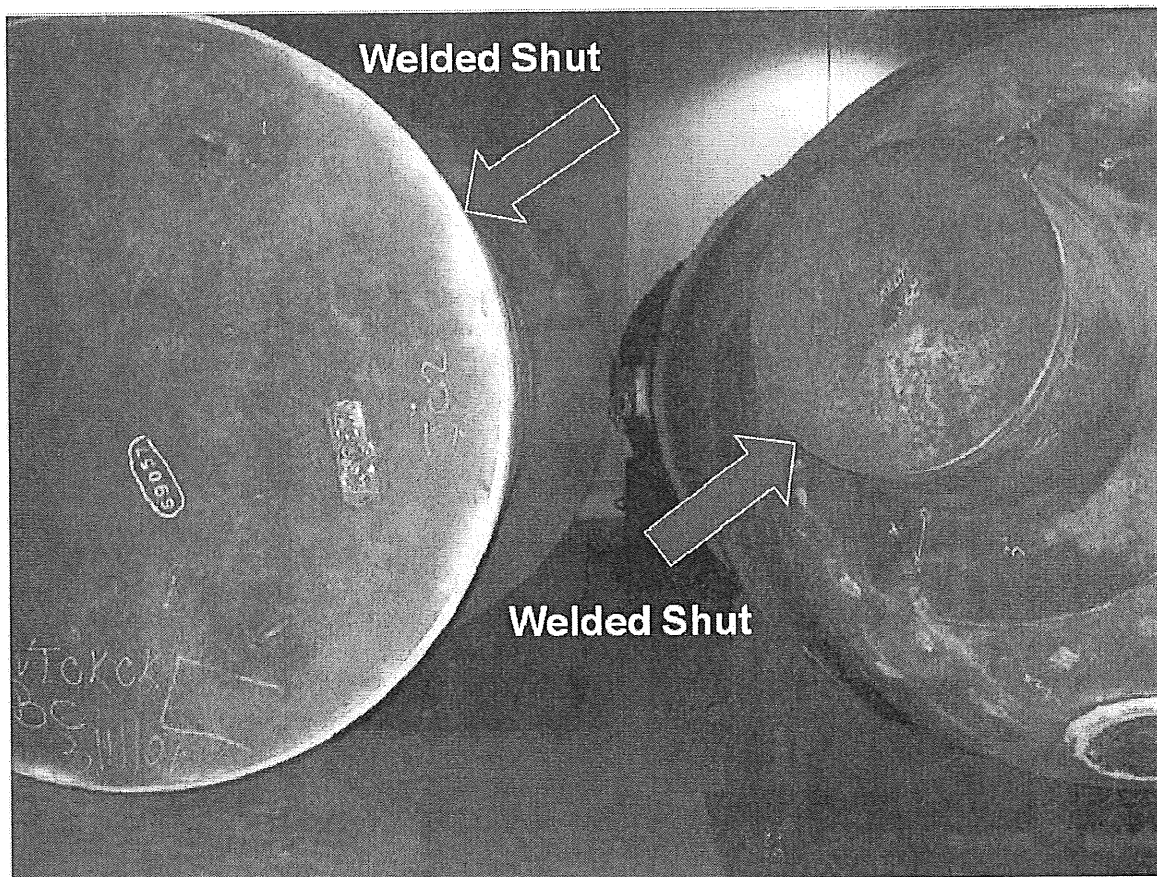

Figure 4: Welding of all openings of the steam generators (detailed view)

4.1.5 Preparatory Work

In preparation for shipment, the exterior of the steam generators would be painted with a 0.15 millimetre thick coat in order to protect the exterior of the steam generators. The preparation work would take place at the WWMF at the Bruce site. The steam generators would be lifted off their current storage saddles and placed onto transport saddles using a gantry jacking system. Once on the transport saddles, a self-propelled modular transporter would be used to move the steam generators individually from the storage area to the staging area (Figure 5). The transport saddles would then be welded to the steam generators and the painting would take place. Additionally, the steam generators would be secured to the saddles using wire rope and a turnbuckle system. Following the preparation work, the steam generators would be moved individually from the staging area to the transfer point using a self-propelled modular transporter.



Figure 5: Steam generator loaded onto a self-propelled modular transporter

4.1.6 Road Transport

CNSC staff evaluated the proposal to transport the steam generators individually by truck, from the Bruce site to the port of Owen Sound, located approximately 90 km north of the Bruce site. Transport would be made along a specified route that has undergone an engineering evaluation and approval by the Province of Ontario. The road transport would have to be made as a heavy load transport; the travelling speed would be limited to 15-20 km/h and would require an escort and special permits from the Province of Ontario and the municipalities along the route. The applicant indicated that they did apply for those permits which can only be issued within 30 days of the planned shipment at the earliest.

The steam generators would be secured to the transport saddles with wire ropes, turnbuckles and welds (Figure 7). Each generator would be loaded onto a heavy haul trailer and transported to Owen Sound where they would be loaded into the closed cargo hold of the ship.

The required speed limitation and road escort would be prescribed in the shipment section of the transport certificate.

4.1.7 Marine Transport

CNSC staff evaluated the details related to the ship to be used, the MV Panthera or one of its sister ships that have been designed for the transport of heavy cargo. These ships, built around the year 2000, are 118 m long and each can transport up to 7000 metric tons of cargo. The only goods to be transported onboard the ship would be the 16 steam generators and their load represents approximately 25 % of the total capacity of the ship. Any fastening required for marine shipment would be installed at this time and the transport saddles of each unit would be welded to the floor of the closed cargo hold of the ship in preparation for the maritime shipment. The ship would travel the Great Lakes, up the St. Lawrence Seaway system, across the Atlantic Ocean and dock at Studsvik, Sweden, where the cargo would be unloaded. Besides Canada, the countries included in the route are the United States (as the Great Lakes and Seaway are shared between Canada and the United States) and Sweden.

Specification that no other cargo may be loaded onboard the ship would be included in the shipment section of the transport certificate.

4.1.8 Compliance with the St. Lawrence Seaway

CNSC staff verified that the vessel complies with the maximum draft permitted in the St. Lawrence Seaway. The ship proposed for this shipment has a maximum draft of 7.25 metres (72.5 dm) when fully loaded, complying with the Seaway draft requirement, and the main channels between the Port of Montreal and Lake Erie have a controlling depth of 8.23 metres. The authority for managing ships on the St. Lawrence Seaway and the Great Lakes is jointly shared by the St. Lawrence Seaway Management Corporation, on the Canadian side, and the Saint Lawrence Seaway Development Corporation, on the American side. Shipments through the Seaway are required to comply with the *Seaway Handbook* promulgated by these authorities. The Handbook addresses issues related to navigating the Seaway, including obtaining approval to transit the Seaway, declaring cargo, allowable specifications for ships, pilotage requirements and vessel communication and tracking. Any vessel wishing to transit the Seaway must comply with the requirements in the Handbook. In addition to the Handbook, the Seaway authorities also issue notices with respect to navigating the Seaway system. For example, Seaway Notice No. 10-2010, dated July 23, 2010, addresses the maximum permissible draft on the Montreal-Lake Ontario section.

CNSC staff confirmed that the steam generators as presented for transport would meet the packaging requirements applicable to all packages. In addition, special supports (transport saddles) were developed for the transport of these steam generators (Figure 6). They have been designed in accordance with the requirements of the *International Maritime Dangerous Goods Code*, and the *International Code for the Safe Carriage of Irradiated Nuclear Fuel, Plutonium and High Level Radioactive Waste on Board Ships* (INF-2 Code) to accommodate and secure the placement of the steam generators in the hold of the ship and would be used for both the road and marine shipment.

The steam generators would be secured to the transport saddles with wire ropes, turnbuckles and welds (Figure 7). Each generator would be loaded onto a heavy haul trailer and transported to Owen Sound where they would be loaded into the cargo hold of the ship.

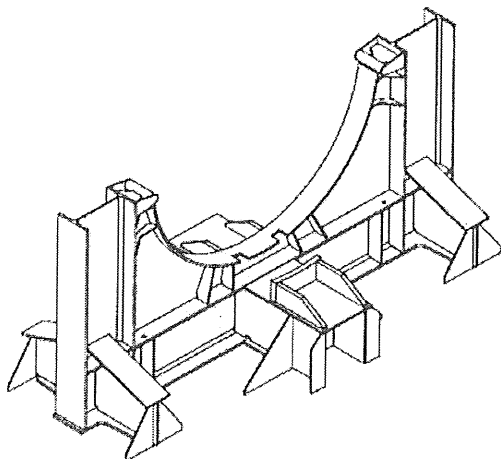

Figure 6: Transport saddle

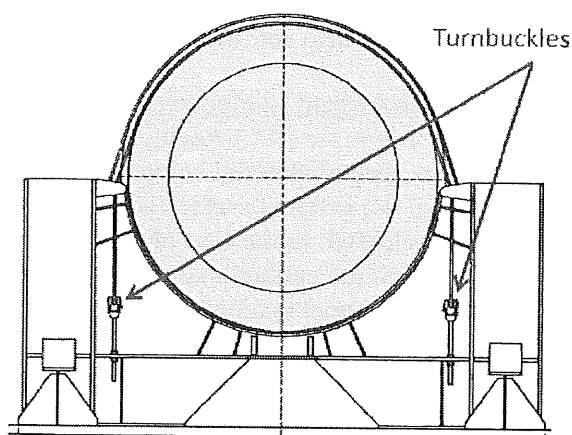

Figure 7: Steam generators as prepared for shipment

CNSC staff evaluated the proposed transport saddles and tie-down system to ensure that, in the event of a severe accident, the tie-down system would fail before the structure of the steam generators. This ensures that the containment is maintained and that the nuclear substances would not be released from these steam generators due to the tie-down configuration in the case of an accident.

CNSC staff assessed the proposed package configuration with respect to the requirements applicable to SCO-I material. CNSC staff has concluded that the proposed packaging configuration and associated tie-down system meet the regulatory requirements applicable for this type of packaging.

The required tie-down configuration to be used for the road and marine shipment would be included in the shipment section of the transport certificate.

4.1.9 Accident Scenarios

CNSC staff considered multiple transportation incident scenarios, occurring during all phases of the handling and transport, both on road and water. Since scenarios during road transport do not experience the flushing effect experienced during immersion in water, the water scenarios bound the potential consequences of loading and transport of the steam generators.

Potential Release of Activity into the Environment Following an Incident Involving Loading of a Single Steam Generator

With respect to the potential release of activity into the environment, the worst case scenario was determined to be a lifting/rigging incident while loading a single steam generator on the ship, with the steam generator hitting the pier prior to falling into the water. In this scenario, CNSC

staff assumed that the steam generator shell was damaged and that some of the internal contamination would be available for release in the water. Although considered unlikely, the amount of activity that could be released from such an incident was evaluated to ensure conservatism in staff assessments. This assessment considered the potential available releases to come from the non-fixed component of the nuclear substances confined to the inaccessible interior of the steam generator and from the mechanical abrasion (scraping) of the fixed contamination that is also confined to the interior of the steam generator.

Release of Abraded Fixed Component. Based on the IAEA guidance document, TS-G-1.1 *Advisory Material for the IAEA Regulations for the Safe Transport of Radioactive Material*, applicable to the type of material being transported, an object is assumed to move in an accident such that 20% of the external surface is scraped and 20% of the fixed contamination from the scraped area is released. In the case of the generators, no contamination is present on the external surfaces since all of the contamination is located on the internal, inaccessible surfaces, including the interior of the Inconel (stainless steel) tubes. Therefore the steam generators would have to suffer extensive damage in an accident, in order to expose any contamination. Even if a breach in the outer shell were to occur, the fixed contamination within the Inconel tubes would remain inaccessible and could not be scraped off.

Although the IAEA guidance applies to external contamination, CNSC staff elected to use it in order to present an upper bound to the consequences resulting from an incident in which only internal contamination is present. Due to the geometry of the steam generators, the potentially releasable contamination resulting from scraping in this scenario was limited to the interior surface of the steam generator channel head (bowl region), which is less than 5% of the total steam generator surface area and thus represents less than 5% of the total activity. Given the geometry of the steam generator and the absence of external contamination, CNSC staff considers this scenario to be conservative.

The total releasable fraction is thus 20% (fraction of surface abraded) times 20% (fraction of fixed contamination abraded from the surface affected) times 5% (fraction of total inventory in abraded area), hence 0.2% of the total radionuclide inventory would potentially be released in an accident of this type.

Release of Non-Fixed Component. Bruce Power has estimated that non-fixed contamination accounts for 4 to 13% of the total activity within each generator. Thus, the releasable component attributable to non-fixed contamination can be bounded by 13% of the total inventory.

Total Possible Release. The total releasable inventory is thus 13% plus 0.2%, or 13.2%.

Based on the IAEA guidance (TS-G-1.1) developed from experience with past transport accidents, a maximum of 1% of the activity that is available for release in a package would actually be released into the environment in a severe accident. This is known as the release fraction. Applying this release fraction to the releasable inventory of 13.2%, CNSC staff calculated that a maximum of 0.132% of the total activity in the steam generator could be released into the water in a worst case accident scenario as described above.

The results of this analysis are discussed further in Section 4.3.2.

Potential Release of Activity into the Environment Following an Incident Transport of Multiple Steam Generators

When considering the consolidated shipment of all 16 generators by ship, the IAEA *TS-R-1* Regulations specify a maximum total activity that can be transported aboard a single ship. Based on the total quantity of material present in the 16 steam generators, the limit for a single vessel containing SCO-I material is exceeded. The applicant presented an analysis demonstrating that although the limit is exceeded, the fact that there is no contamination on the surface of the steam generator and that only a small fraction of the internal contamination is not fixed, the intent of the regulations is respected. In order to assess the equivalent level of safety of the shipment, CNSC staff performed a detailed analysis of various accident scenarios. An accident involving the breach of the shell of all 16 steam generators was considered as a plausible worst case scenario and used to determine if the level of safety of the activity of the proposed shipment was at least equivalent to the amount authorized in the regulations for a single conveyance.

All of the contamination in the steam generators is located on inaccessible surfaces confined and sealed inside the steel shell of the generators. Furthermore, 95% of the fixed contamination is located on and within the stainless steel tubes with no contact to the outer shell. The steam generators are sealed steel vessels that were constructed as pressure vessels, with a nominal shell thickness of 54 mm. In addition, steel transport saddles have been designed to meet the more stringent requirements applicable to the transport of irradiated nuclear fuel, even though the material transported is not irradiated nuclear fuel and classified as low level SCO-I. The tie down system was designed so that in normal and accident conditions of transport, the forces in those attachments would not result in a breach of containment or hinder the performance of the package. On the ship, all 16 steam generators would be stowed within an enclosed cargo hold.

CNSC staff performed a detailed analysis of various accident scenarios and given the extremely low probability associated with the severe accident scenarios examined, CNSC staff have concluded that the overall level of safety in transport of all 16 steam generators on a single ship is at least equivalent to the amount authorized in the regulations for a single conveyance and that there is no radiological impact on the environment, public and workers.

4.1.10 Compensatory Measures

CNSC staff evaluated the following compensatory measures proposed by the applicant to provide an adequate level of safety during the transport of the 16 steam generators to Sweden:

- A detailed emergency response plan developed to provide administrative controls covering all aspect of the transport
- Security and radiation protection controls to be put in place while the generators are at the Port of Owen Sound
- Radiation Protection personnel to escort all road shipments within Canada
- Maritime shipment to be completed via a special dedicated ship with a radiation safety officer on board at all time.

CNSC staff evaluated the proposed compensatory measures for the transport of the steam generators and concluded that the proposed measures are adequate for the level of risk associated

with the shipment. CNSC staff conclude that the proposed compensatory measures would ensure that the overall level of safety during transport and during storage in transit would be at least equivalent to that which would be provided if all the applicable requirements had been satisfied.

The required compensatory measures would be included in the compensatory measures section of the transport certificate.

4.2. Radiation Protection

The *Radiation Protection Regulations* require licensees to establish a radiation protection program to keep exposures as low as reasonably achievable (ALARA), taking economic and social factors into account, through the implementation of a number of control programs, including:

- Management control over work practices;
- Personnel qualification and training;
- Control of occupational and public exposures to radiation; and
- Planning for unusual situations.

The *Radiation Protection Regulations* also prescribe dose limits for workers and members of the public.

CNSC staff has reviewed Bruce Power's Units 1 and 2 steam generator classifications for transport purposes and the Transportation Emergency Response Plan provided by Bruce Power and no radiation protection issues or concerns have been identified.

All radiological work activities during the preparation of the steam generators for transport would be performed in accordance with the Bruce Power Inc. Radiation Safety Program. CNSC staff has reviewed Bruce Power's radiation safety program as it relates to the transport of the steam generators and conclude that the overall program meets the CNSC requirements.

A person qualified in Radiation Protection would accompany the steam generators at all times and in addition, all activities carried out by the crew on board the ocean-going vessel would be performed in accordance with the vessel's Competent Authority approved radiation protection program, regulated by the Department of Marine Services and Merchant Shipping Antigua and Barbuda W.I..

CNSC staff performed a detailed assessment of Bruce Power's radiation protection program in terms of the following:

- Dose Rate Estimates from the Steam Generators;
- Radioactive Contamination Control Measures;
- Accident Scenarios;
- Radiation Doses to Workers; and
- Radiation Doses to Members of the Public.

CNSC staff has concluded that adequate provisions have been put in place to ensure the control of doses for the overall transport operation.

4.2.1 Dose Rate Estimates from the Steam Generators

Bruce Power has performed detailed dose rate measurements from the steam generators in 2007 prior to their transfer from the Bruce A site to the WWMF. Most of the dose rates from the steam generators were less than 100 micro Sievert per hour ($\mu\text{Sv/h}$) on contact.

The maximum contact dose rate found on any steam generator was 270 $\mu\text{Sv/h}$ and the maximum dose rate at 1 meter was 80 $\mu\text{Sv/h}$.

Since the steam generators were moved to the WWMF for storage, OPG has periodically verified the radiation dose in and around the storage location.

As part of a CNSC field inspection on July 26, 2010, CNSC staff measured the dose rate, on contact, on two steam generators. The maximum dose rate measured on contact from the steam generators was 90 $\mu\text{Sv/h}$.

As required by the PTNS Regulations, Bruce Power personnel would perform radiation survey measurements of all steam generators as they are prepared for shipment from the Bruce site. Additionally, measurements would be taken by CNSC staff on the Bruce site and once the steam generators are loaded onboard the vessel.

4.2.2 Radioactive Contamination Control Measures

The radioactive contamination is limited to the interior surfaces of the steam generators. There is no radioactive contamination on any accessible surfaces above the allowable contamination limits for transport.

Prior to the transfer of the steam generators from the Bruce A to WWMF at the Bruce site, the accessible surfaces of each steam generators were decontaminated to a level below the safe contamination limits applicable for transport. For the non-fixed contamination, the regulatory limit averaged over 300 cm^2 is 4 Bq/cm^2 for gamma, beta and low toxicity alpha emitters, and 0.4 Bq/cm^2 for other alpha emitters. For the fixed contamination, the regulatory limit averaged over 300 cm^2 , is 4×10^4 Bq/cm^2 for gamma, beta and low toxicity alpha emitters, and 4×10^3 Bq/cm^2 for other alpha emitters.

As part of a CNSC field inspection on July 26, 2010, CNSC staff took wipe tests on the surface of two steam generators to verify the absence of loose contamination. The wipes were independently analyzed by the CNSC laboratory and no loose surface contamination was detected on the samples.

Bruce Power would perform surface contamination surveys on the surface of each steam generator during the preparation of the steam generators to verify the levels of loose contamination in order to ensure compliance with the contamination limits. Any loose contamination found on any accessible areas would be removed prior to shipment. Furthermore,

prior to transportation, the exterior of each steam generator would be coated with a paint-like fixative.

4.2.3 Radiation Doses to Workers

As required by the CNSC, all preparatory radiological activities of the steam generators would be performed in accordance with the Bruce Power Inc. Radiation Protection Program (BP-PROG-12.05) and more specifically with Bruce Power's procedure BP-RPP-00013, *Radioactive Shipment*.

As specified by the Radiation Protection Program, all workers on land would be wearing thermoluminescent dosimeters (TLDs) and Electronic Personal Dosimeters (EPDs) to measure the "whole-body" and "skin" doses they may receive.

All radiological activities carried out onboard the sea going vessel by the crew would be performed in accordance with the vessel's Radiation Protection Program approved by the Competent Authority responsible for the ship. Workers involved in radiological activities would be wearing dosimeters to measure "whole-body" and "skin" doses they may receive.

CNSC staff reviewed the radiation protection programs submitted in the application and conclude that the overall program meets the ALARA principle and the CNSC regulatory requirements.

References to the radiation protection program that are to be followed for the shipment would be included in the shipment section of the transport certificate.

4.2.4 Radiation Doses to member of the Public

CNSC staff verified the dose estimates for members of the public related to the road shipment. CNSC staff conclude that the dose to members of the public would be negligible. The dose for people driving or walking by the steam generators while they are in transit on the highway would be less than 1 percent of the regulatory limit of 1 mSv (1000 μ Sv) applicable to members of the public.

CNSC staff concluded that appropriate radiation safety measures have been proposed by Bruce Power to protect the health and safety of the workers and the public.

4.3. Environmental Impact

4.3.1 Discussion Environmental Assessment under CEAA

CNSC staff reviewed the application from Bruce Power to determine if this activity requires an environmental assessment under the *Canadian Environmental Assessment Act*. The packaging and transport of the steam generators is an activity that is not within the class of activities prescribed pursuant to the regulations made under paragraph 59(b) of that Act and does not meet the definition of a project in the Act. Therefore, it is not subject to section 2 of the CEAA and CEAA does not apply.

In accordance with CEAA and its regulations, CNSC staff has determined that an environmental assessment is not required.

4.3.2 Environmental Protection

In addition to the environmental assessment that was prepared in 2006 as part of the refurbishment of Bruce Unit 1 and 2, CNSC staff performed an environmental impact assessment of the project under the NSCA to consider whether adequate measures for the protection of the environment would be in place. CNSC staff conclude that under the normal or expected conditions of transport, there would not be an impact on the health and safety of persons and the environment because all contamination is sealed within the steam generators.

CNSC staff assessed the protection of drinking water supplies as a bounding environmental and human health scenario for an accident during the loading and marine transport of Bruce Power steam generators from Owen Sound to Sweden.

The consequences of a partial release of the inventory (0.132%) from one steam generator were assessed for a credible, but very low probability accident: a near shore accidental release before expected salvage operations mitigated any impacts. The release was assumed to take place very close to a drinking water supply plant on a major body of water on the Great Lakes. The expected dilution pattern in time and space was extrapolated from detailed measurements taken during a major spill of tritium into Lake Ontario at the Pickering Nuclear Generating Station in August of 1992. This dilution potential was compared to the dilution required to not exceed the Health Canada Action Levels for the protection of drinking water supplies following nuclear emergencies. For a mixture of nuclear substances as in this scenario, estimated concentrations in drinking water were divided by each Action Level and summed across all nuclear substances to provide a fraction of the integrated Action Level across all nuclear substances, as in Health Canada guidance. Each Action Level is based on an intervention level of 1 millisievert (1 mSv, also the CNSC public dose limit) applied independently to drinking water and to two other food groups. These Action Levels are recommended for use in the context of intervening in terms of withdrawal or substitution of food and drinking water following a nuclear emergency.

Based on conservative assumptions, CNSC staff found that during this type of very low probability accident, concentrations of radioactivity in drinking water in the near-field a day after the event would be no more than 0.33% of the integrated Action Level for all nuclear substances. CNSC staff conclude that there is an abundant safety margin for the protection of drinking water during marine loading and transport.

This overall conclusion should be applicable even if the environmental dilution factors based on the 1992 tritium spill are not entirely applicable, or the amount of material released approaches the inventory of a single steam generator. Hence, CNSC staff conclude that the environmental and human health risk from a release due to a credible accident or malfunction during loading and transport would be very low.

4.4. Emergency Measures

Applicants are required to establish an emergency response program to define the actions that would be taken in an emergency situation, including:

- Emergency management
- Mitigation and recovery
- Emergency response

4.4.1 Emergency Management

CNSC staff assessed the emergency response plan submitted with the application. The emergency response plan discusses the actions that would be taken should an emergency situation arise such as notifications, reporting, emergency management and response. Response procedures for worst case scenario accidents that could occur while the steam generators are in transit either by road or vessel, and also while being loaded onto and unloaded from the vessel were also provided. Resources, personnel and 3rd party contractors were identified to undertake the procedures to protect personnel, the environment and the health and safety of the public.

The shipboard emergency plan gives guidance that is to be followed in emergency situations that could potentially arise on the vessel for Irradiated Nuclear Fuel (INF) Cargo. Although the steam generators are not considered INF cargo, the INF plan is being used. The INF plan is a more restrictive, careful plan. The intent of the plan is to prevent injuries to crew, minimize or prevent any damage to the vessel and cargo, and also allow the captain to regain control of the vessel should an emergency arise. The plan gives detailed procedures to be followed on roles and responsibilities of the emergency response teams, communication protocols, notification and reporting procedures and also prevention and reduction of contamination from nuclear substances.

The shipboard emergency plan is approved by the Competent Authority of the ship's flag state, the Department of Marine Services and Merchant Shipping Antigua and Barbuda W.I., as meeting the requirements of the *International Maritime Dangerous Goods Code*.

4.4.2 Mitigation and Recovery

An inventory of resources and equipment for emergency response are detailed in the application for any mitigation and recovery operations that would be undertaken in the event of an emergency.

4.4.3 Emergency Response

The initial cordon area for safety in the event of an accident is 91.4 meters (300 feet) from the steam generators. This is considered by CNSC staff to be an adequate safe distance from the incident. The application lists the responses to be taken for: public safety, personnel safety, protection of the conveyance, and protection of the package. It also lists responses to be taken to mitigate, respond to and recover from an emergency situation.

Communication for emergency response would be established by hand held radios at the emergency location and cell phones would be used to communicate away from the emergency area.

CNSC staff has reviewed the emergency response plan submitted with the application.

CNSC staff conclude that the emergency measures that would be in place for this shipment to protect the health and safety of the workers and the public are adequate.

4.5. Security

A preliminary transport security plan was submitted by Bruce Power to cover this shipment and CNSC staff reviewed and approved this preliminary plan. The details regarding the plan submitted are included in a separate CMD and will not be made available due to security reasons. Bruce Power is required to submit a final security plan prior to the planned shipment of the steam generators.

5.0 CONSULTATION

As part of good governance, letters of notification about the Bruce Power steam generator application were sent on June 23 and July 9 to the Saugeen Ojibway Nation, the Historic Saugeen Métis and the Grey Owen Sound Métis Council regarding the application from Bruce Power and offered to provide information.

At the invitation of the Mayor, on July 26, 2010 the CNSC made a presentation to the Owen Sound City Council on the topic of the transportation of steam generators from the Bruce Power nuclear site to Sweden for recycling. The presentation covered CNSC's mandate and licensing process, applicable regulations, the scope of the CNSC's evaluation, details of the Bruce Power application and the required approvals at all levels. Following the presentation, CNSC staff answered questions from the Mayor and councillors.

This same presentation was delivered in St. Catharines, Ontario, to the Mayors and fire chiefs of St. Catharines and Port Colborne, as well as to the Mayor of Thorold, at their request.

6.0 OVERALL CONCLUSION

CNSC staff conclude that the shipment would comply with applicable national and international regulations.

CNSC staff performed an evaluation of the inventory of the nuclear substances present and concluded that the activity contained within the steam generator has been adequately estimated.

CNSC staff verified the assumptions used in the application and confirms the decay calculations performed by the applicant. CNSC staff confirm the classification of the steam generators as SCO-I material as per the Regulations.

CNSC staff assessed the proposed package configuration with respect to the requirements applicable to SCO-I material and Type IP-1 packages. CNSC staff conclude that the proposed

tie-down and configuration meets the regulatory requirements applicable for this type of packaging.

CNSC staff evaluated the proposed compensatory measures for the transport of the steam generators and concluded that the proposed measures are commensurate with the level of risk associated with the shipment.

CNSC staff conclude that the proposed compensatory measures would ensure that the overall level of safety during transport and during storage in transit would be at least equivalent to that which would be provided if all the applicable requirements had been satisfied.

CNSC staff has concluded that adequate provisions have been put in place to ensure the control of doses for the overall transport operation. CNSC staff conclude that appropriate radiation safety measures have been proposed by Bruce Power to protect the health and safety of the workers and the public.

In accordance with CEAA and its regulations, CNSC staff has determined that an environmental assessment is not required. For the protection of the environment, CNSC staff concludes that the environmental and human health risk from a release due to a credible accident during loading and transport would be very low.

CNSC staff conclude that the emergency measures that would be in place for this shipment to protect the health and safety of the workers and the public are adequate.

7.0 RECOMMENDATION TO THE COMMISSION

CNSC staff recommend that the Commission approve:

- 1) The attached proposed transport licence number TL-SX-40039.01.00/2010 for the transport of the 16 steam generators to Sweden
- 2) The attached proposed transport certificate number CDN/5255/X-96 (Rev.0) for the transport of the 16 steam generators to Sweden.

CNSC staff recommend that the licence and certificate be issued for a period of 1 year.

REFERENCES

- [1] Bruce Power application dated April 1, 2010; Application for a Licence to Package and Transport Steam Generators under Special Arrangement, (Document number 3530083)
- [2] Bruce Power Response to CNSC staff questions dated July 22, 2010 (Document number 3585939)
- [3] Bruce Power Revised Application date August 06, 2010 (Document number 3592671)
- [4] Bruce Power Response to CNSC staff questions dated August 10, 2010 (Document 3593184)
- [5] Bruce Power Response to CNSC staff questions dated August 17, 2010 (Document 3595816)
- [6] Bruce Power Response to CNSC staff questions dated August 17, 2010 (Document 3596840)

LIST OF ACRONYMS

ALARA: As Low As Reasonable Achievable

CEAA: *Canadian Environmental Assessment Act*

CMD: Commission Meeting Document

CNSC: Canadian Nuclear Safety Commission

DO: Designated Officer

EPD: Electronic Personal Dosimeters

ERAP: Emergency Response Assistance Plan

IAEA: International Atomic Energy Agency

IMDG: International Maritime Dangerous Goods

IMO: International Maritime Organization

INF: Irradiated Nuclear Fuel

NSCA: *Nuclear Safety and Control Act*

OPG: Ontario Power Generation

PTNS: *Packaging and Transport of Nuclear Substances*

SCO-1: Surface Contaminated Objects – Group 1

TDG: *Transportation of Dangerous Goods*

TLD: Thermoluminescent Dosimeters

WWMF: Western Waste Management Facility

DEFINITIONS

Surface Contaminated Object

Means a solid object which is not itself radioactive but which has radioactive material distributed on its surface where:

- The non-fixed contamination on the accessible surfaces does not exceed 4 Bq/cm^2 in any 300 cm^2 for beta and gamma emitters and low toxicity alpha emitters and 0.4 Bq/cm^2 for other alpha emitters.
- The fixed contamination on the accessible surfaces does not exceed $4 \times 10^4 \text{ Bq/cm}^2$ in any 300 cm^2 for beta and gamma emitters and low toxicity alpha emitters and $4 \times 10^3 \text{ Bq/cm}^2$ for other alpha emitters.
- The non-fixed and fixed contamination in inaccessible areas does not exceed $4 \times 10^4 \text{ Bq/cm}^2$ in any 300 cm^2 for beta and gamma emitters and low toxicity alpha emitters and $4 \times 10^3 \text{ Bq/cm}^2$ for other alpha emitters.

Special Arrangement:

Means the provisions, approved by the competent authority, under which shipments that do not meet all the applicable requirements of the IAEA *TS-R-1* Regulations may be transported. This type of shipment is intended for those situations where the normal requirements cannot be met, for example, the disposal of old equipment containing radioactive material where there is no reasonable way to transport the radioactive material in an approved package. The competent authority must be satisfied that conformity with the provisions of the IAEA *TS-R-1* Regulations is impracticable and that the overall level of safety in transport is at least equivalent to that which would be provided if all the applicable requirements had been met.

APPENDIX A: DRAFT TRANSPORT LICENCE TL-SX-40039.01.00/2010



I) LICENSEE

Pursuant to subsection 24(2) of the Nuclear Safety and Control Act, this licence is issued to:

Bruce Power Incorporated
177 Tie Road, RR2
Tiverton, Ontario
N0G 2T0

II) LICENCE PERIOD

This licence is valid from September 29, 2010 to September 30, 2011, unless otherwise suspended, revoked or replaced.

III) LICENSED ACTIVITY

This licence authorizes the licensee to package and transport under special arrangement the nuclear substances and prescribed equipment listed in Section IV of this licence.

IV) NUCLEAR SUBSTANCES AND PRESCRIBED EQUIPMENT

Package Item	Nuclear Substance	Maximum Total Activity of Consignment	Package Design Certificate	No. of Packages
Steam Generator	Surface Contaminated Object Group-1 (SCO-I)	3.67 TBq	CDN/5255/X-96	16

V) LOCATION OF LICENSED ACTIVITY

The licensed activity is to be carried out while the package is to be transported under exclusive use by road from the Bruce Power, Tiverton Ontario to Owen Sound, Ontario and by vessel to Studsvik facility in Sweden.

VI) CONDITIONS

1. The licensee shall carry out the licensed activity in accordance with:
 - (a) the information contained in the application by Bruce Power to the Canadian Nuclear Safety Commission, dated April 1, 2010 and as supplemented July 22, 2010, August 6, 2010, August 10, 2010 and August 17, 2010, under CNSC Reference Numbers 3530083, 3585939, 3592671, 3593184, 3595816, 3596840; and
 - (b) the limitations, terms and conditions specified in Canadian Certificate No. CDN/5255/X-96, (Rev. 0) attached as Appendix A to this licence.
2. The Appendix forms part of this licence.
3. The licensee shall report in writing to the Canadian Nuclear Safety Commission any planned changes or deviations from the information contained in the application prior to their implementation.
4. The licensee shall report in writing to the Canadian Nuclear Safety Commission any unplanned changes or deviations from the information contained in the application, as supplemented, no later than 5 working days after the change or deviation is in effect.



Canadian Nuclear Safety Commission
Commission canadienne de sûreté nucléaire

LICENCE TO TRANSPORT PERMIS DE TRANSPORT

Licence Number
Numéro de permis
TL-SX-40039.01.00/2010

5. The licensee shall:
- (a) ensure that the Preliminary Security Plan Number TSP-2010-08-06 VN1, referenced in the application by Bruce Power Incorporated to the Canadian Nuclear Safety Commission, dated August 6, 2010 under CNSC Reference Number 3592668 applicable to the licensed activity, as supplemented, is in effect during the licence period; and
 - (b) 24 hours prior to carrying out the licensed activity, submit in writing to the Canadian Nuclear Safety Commission a final security plan supplementing the Preliminary Security Plan referenced in paragraph (a). The licensee shall provide advance notification of the shipment to the Canadian Nuclear Safety Commission, Ottawa by facsimile (613) 995-5086 not less than two working days prior to the departure of the shipment.
6. The licensee shall, immediately after the completion of the shipment, submit a written report to the Canadian Nuclear Safety Commission confirming completion of the shipment, and other information on any difficulties experienced and any deviations from the certificate or license applicable to the shipment.

Dr. Michael Binder
President
Canadian Nuclear Safety Commission



Appendix A

Canadian Certificate No. CDN/5255/X-96 (Rev. 0)	Issue Date	Expiry Date Sep-30-2011	CNSC File 30-B4-100-0
--	------------	----------------------------	--------------------------

Certificate for Special Arrangement

The package identified below is certified by the Canadian Nuclear Safety Commission in accordance with paragraph 21(1)(h) of the *Nuclear Safety and Control Act* and Section 5 of the *Packaging and Transport of Nuclear Substances Regulations*, to the 1996 Edition (Revised) of the *IAEA Regulations for the Safe Transport of Radioactive Material* for transport under Special Arrangement; subject to the following limitations, terms and conditions.

This certificate does not relieve the consignor from compliance with any requirement of the government of any country through or into which the package will be transported, or any other applicable regulatory requirements.

This certificate is valid only when used under CNSC Licence No. TL-SX-40039.01.00/2010.

PACKAGE IDENTIFICATION

Designer: **Bruce Power Inc.**
Make/Model: **Unit 1 and 2 Steam Generators**
Mode of Transport: **Sea, Road**

IDENTIFICATION MARK

The package shall bear the competent authority identification mark "CDN/5255/X- 96".

PACKAGE DESCRIPTION

The package consists of a steam generator that was qualified as a pressure retaining component when in use. It is composed of a 54-millimetre thick exterior steel wall containing 4,200 inconel stainless steel tubes, each measuring 14 meters in length by 11 millimetres in diameter. In total, there are 16 steam generators to which this certificate applies. The steam generators are non-radioactive equipment used in Bruce Power's nuclear power stations. At the end of their service life within the reactor station they were internally contaminated with metal oxides that are radioactive.

The configuration of the package is as follows:

Shape:	Cylindrical	Shielding:	n/a
Mass:	90800 kg	Outer Casing:	Steel
Length:	11.7 mm	Height:	n/a
Width:	n/a	Diameter:	2500 mm

AUTHORIZED RADIOACTIVE CONTENTS

The total activity contained in the 16 steam generators has been estimated at 3.67 TBq as of June 30, 2010. Refer to Appendix 1 for the list of radionuclides present in each steam generator from Unit 1 and Unit 2.



COMPENSATORY MEASURES

Compensatory measures have been put in place to compensate for the regulatory requirements that could not be met to ensure that the overall level of safety during transport and during storage in transit would be at least equivalent to that which would be provided if all the applicable requirements had been satisfied. The compensatory measures consist of: an emergency response plan developed to provide administrative controls covering all aspects of the transport; security and radiation protection controls while the generators are at the Port of Owen Sound, Ontario (Canada); radiation protection personnel to escort the road shipments; and the use of a special dedicated vessel with a radiation safety officer on board at all time.

SHIPMENT

- The steam generators shall be transported under exclusive use by road from Bruce Power, Tiverton, Ontario to the Port of Owen Sound, Owen Sound, Ontario and by exclusive use vessel from the Port of Owen Sound to Studsvik Facility in Sweden.
- The vessel shall not carry any other cargo.
- The steam generators shall be secured for transport using wire ropes and turnbuckles as specified in Annex 2 of the application dated April 1, 2010 and its supplement dated July 22, 2010 (CNSC Reference Numbers 3530083 and 3585939).
- The transport vehicle for the road portion of the shipment shall travel at speeds not exceeding 20 km/h and shall be escorted at all times by a Bruce Power representative knowledgeable in the hazards associated with radiation protection.
- Non-fixed radioactive contamination shall not exceed the limits prescribed in Paragraph 508 of the IAEA Regulations.
- The packages shall be labelled on two opposite sides, on the external surface of the package, with III-Yellow radioactive material labels; the consignor's and consignee's name and addresses. In addition, the competent authority identification mark "CDN/5255/X-96" shall also be present.
- The transport vehicle shall be placarded on each side and each end according to Subsection 16(4) of the *Packaging and Transport of Nuclear Substances Regulations* and the *Transport of Dangerous Goods Regulations*.
- Only those personnel involved with the shipment shall be carried in the road vehicle.
- The maritime shipment shall be made under exclusive use in a dedicated ship and a radiation safety officer on board at all time.
- Communication for emergency response shall be established by hand held radios at the emergency location and cell phones for communication away from the emergency area.
- The emergency response plan shall be in accordance with the information supplied in the original application dated April 1, 2010 and its supplements dated July 22, 2010, August 6, 2010 and August 10, 2010 (CNSC Reference Numbers 3530083, 3585939, 3592671 and 3593184).
- The security and radiation protection controls shall be put in place while the steam generators are at the Port of Owen Sound.
- All radiological activities shall be performed in accordance with the Bruce Power Inc. Radiation Protection Program (BP-PROG-12.05), Bruce Power Procedure BP-RPP-00013, *Radioactive Shipment* and all activities onboard the vessel shall be performed in accordance with the vessel's Radiation Protection Program.
- A report shall be submitted to the CNSC within fourteen days after expiration of this certificate. The report shall summarize the shipments made under the authority of this certificate during the reporting period and detail any difficulties experienced and deviations from the conditions listed.

Dr. Michael Binder
President
Canadian Nuclear Safety Commission



Appendix 1

Activity by isotope for the respective reactor Unit.

Isotope	Activity Unit 1 (MBq)	Activity Unit 2 (MBq)
Am-241	16,100	13,200
Am-243	16	18
C-14	1,500	12,000
Cm-244	8,240	1,080
Co-60	84,700	41,800
Cs-137	821	783
Eu-154	291	247
Fe-55	24,300	33,300
H-3	21,500	19,200
Hf-181	674	652
I-129	0.000390	0.000390
Nb-94	15	15
Ni-59	520	110
Ni-63	66900	14400
Np-237	0.75	0.87
Pu-238	4800	3010
Pu-239	4900	5700
Pu-240	6990	8090
Pu-242	7.1	8.2
Sb-125	41.1	2.47
Sr-90	47,100	39,300
Tc-99	0.09	0.058

APPENDIX B: DRAFT CERTIFICATE CDN/5255/X-96 (REV. 0)



Canadian Certificate No. CDN/5255/X-96 (Rev. 0)	Issue Date	Expiry Date Sep-30-2011	CNSC File 30-B4-100-0
---	------------	-----------------------------------	---------------------------------

Certificate for Special Arrangement

The package identified below is certified by the Canadian Nuclear Safety Commission in accordance with paragraph 21(1)(h) of the *Nuclear Safety and Control Act* and Section 5 of the *Packaging and Transport of Nuclear Substances Regulations*, to the 1996 Edition (Revised) of the *IAEA Regulations for the Safe Transport of Radioactive Material* for transport under Special Arrangement; subject to the following limitations, terms and conditions.

This certificate does not relieve the consignor from compliance with any requirement of the government of any country through or into which the package will be transported, or any other applicable regulatory requirements.

This certificate is valid only when used under CNSC Licence No. TL-SX-40039.01.00/2010.

PACKAGE IDENTIFICATION

Designer: **Bruce Power Inc.**
Make/Model: **Unit 1 and 2 Steam Generators**
Mode of Transport: **Sea, Road**

IDENTIFICATION MARK

The package shall bear the competent authority identification mark "**CDN/5255/X - 96**".

PACKAGE DESCRIPTION

The package consists of a steam generator that was qualified as a pressure retaining component when in use. It is composed of a 54-millimetre thick exterior steel wall containing 4,200 inconel stainless steel tubes, each measuring 14 meters in length by 11 millimetres in diameter. In total, there are 16 steam generators to which this certificate applies. The steam generators are non-radioactive equipment used in Bruce Power's nuclear power stations. At the end of their service life within the reactor station they were internally contaminated with metal oxides that are radioactive.

The configuration of the package is as follows:

Shape: Cylindrical	Shielding: n/a
Mass: 90800 kg	Outer Casing: Steel
Length: 11.7 mm	Height: n/a
Width: n/a	Diameter: 2500 mm



Canadian Certificate No. CDN/5255/X-96 (Rev. 0)	Issue Date	Expiry Date Sep-30-2011	CNSC File 30-B4-100-0
--	------------	----------------------------	--------------------------

AUTHORIZED RADIOACTIVE CONTENTS

The total activity contained in the 16 steam generators has been estimated at 3.67 TBq as of June 30, 2010.

Refer to Appendix 1 for the list of radionuclides present in each steam generator from Unit 1 and Unit 2.

COMPENSATORY MEASURES

Compensatory measures have been put in place to compensate for the regulatory requirements that could not be met to ensure that the overall level of safety during transport and during storage in transit would be at least equivalent to that which would be provided if all the applicable requirements had been satisfied. The compensatory measures consist of: an emergency response plan developed to provide administrative controls covering all aspects of the transport; security and radiation protection controls while the generators are at the Port of Owen Sound, Ontario (Canada); radiation protection personnel to escort the road shipments; and the use of a special dedicated vessel with a radiation safety officer on board at all time.

SHIPMENT

- The steam generators shall be transported under exclusive use by road from Bruce Power, Tiverton, Ontario to the Port of Owen Sound, Owen Sound, Ontario and by exclusive use vessel from the Port of Owen Sound to Studsvik Facility in Sweden.
- The vessel shall not carry any other cargo.
- The steam generators shall be secured for transport using wire ropes and turnbuckles as specified in Annex 2 of the application dated April 1, 2010 and its supplement dated July 22, 2010 (CNSC Reference Numbers 3530083 and 3585939).
- The transport vehicle for the road portion of the shipment shall travel at speeds not exceeding 20 km/h and shall be escorted at all times by a Bruce Power representative knowledgeable in the hazards associated with radiation protection.
- Non-fixed radioactive contamination shall not exceed the limits prescribed in Paragraph 508 of the IAEA Regulations.
- The packages shall be labelled on two opposite sides, on the external surface of the package, with III-Yellow radioactive material labels; the consignor's and consignee's name and addresses. In addition, the competent authority identification mark "CDN/5255/X-96" shall also be present.
- The transport vehicle shall be placarded on each side and each end according to Subsection 16(4) of the *Packaging and Transport of Nuclear Substances Regulations* and the *Transport of Dangerous Goods Regulations*.



Canadian Certificate No. CDN/5255/X-96 (Rev. 0)	Issue Date	Expiry Date Sep-30-2011	CNSC File 30-B4-100-0
--	------------	----------------------------	--------------------------

- Only those personnel involved with the shipment shall be carried in the road vehicle.
- The maritime shipment shall be made under exclusive use in a dedicated ship and a radiation safety officer on board at all time.
- Communication for emergency response shall be established by hand held radios at the emergency location and cell phones for communication away from the emergency area.
- The emergency response plan shall be in accordance with the information supplied in the original application dated April 1, 2010 and its supplements dated July 22, 2010, August 6, 2010 and August 10, 2010 (CNSC Reference Numbers 3530083, 3585939, 3592671 and 3593184).
- The security and radiation protection controls shall be put in place while the steam generators are at the Port of Owen Sound.
- All radiological activities shall be performed in accordance with the Bruce Power Inc. Radiation Protection Program (BP-PROG-12.05), Bruce Power Procedure BP-RPP-00013, *Radioactive Shipment* and all activities onboard the vessel shall be performed in accordance with the vessel's Radiation Protection Program.
- A report shall be submitted to the CNSC within fourteen days after expiration of this certificate. The report shall summarize the shipments made under the authority of this certificate during the reporting period and detail any difficulties experienced and deviations from the conditions listed.

Dr. Michael Binder
President
Canadian Nuclear Safety Commission



Appendix 1

The package shall not contain more than the following activity for the respective reactor Unit.

Isotope	Activity Unit 1 (MBq)	Activity Unit 2 (MBq)
Am-241	16,100	13,200
Am-243	16	18
C-14	1,500	12,000
Cm-244	8,240	1,080
Co-60	84,700	41,800
Cs-137	821	783
Eu-154	291	247
Fe-55	24,300	33,300
H-3	21,500	19,200
Hf-181	674	652
I-129	0.000390	0.000390
Nb-94	15	15
Ni-59	520	110
Ni-63	66900	14400
Np-237	0.75	0.87
Pu-238	4800	3010
Pu-239	4900	5700
Pu-240	6990	8090
Pu-242	7.1	8.2
Sb-125	41.1	2.47
Sr-90	47,100	39,300
Tc-99	0.09	0.058